



Formula 1  
2018 Singapore Airlines  
Singapore Grand Prix  
Singapore 14-16 September

# in Schools

World Finals Singapore 2018

## EVENT REPORT





# F1 in Schools

World Finals Singapore 2018

"It has been a fantastic world finals, a real celebration of the outstanding talents of our students from across the globe, but there can only be one world champion and my congratulations go to Horizon, from a team from down under who graced the top step of the podium."



With seven all-girls teams this year and 40% females, we're representing the increasing popularity of STEM with girls, who bring so much to our programme. F1 in Schools is just like Formula 1 in miniature and we hope that we inspire more and more students to pursue careers in the sport.

We are also seeing more F1 teams recruit from F1 in Schools and by selecting our best students this re-emphasises the level of talent we are producing. Finally, I would like to thank Chase and Wendy Carey for attending and taking time to meet all of our teams and of course all the Formula 1 teams for their continued support at our world finals."

Andrew Denford  
Founder and Chairman,  
F1 in Schools™



## Gary Anderson, Chair of Judges

*It was a pleasure to return to Singapore to be the Chair of Judges at the 2018 world finals.*

*The talent of the students at the world finals is always exceptional and this year was no different. The level of entrepreneurship and engineering excellence exceeded all expectations and I have learnt to always expect the unexpected from these students.*

*New technologies and innovations have really pushed the competition to its limits. Alongside the intense competition, the sportsmanship and engagement between teams is something that can be truly admired.*

*Well done to all the students who made it to the World Finals and congratulations to our new world champions, Horizon on their superb achievement.*

**Gary Anderson**

## David Croft, Host

*It was great to be back in Singapore hosting the F1 in Schools world finals and yet again I was blown away with the level of innovation, creativity and engineering the students displayed which resulted in a very competitive World Finals.*

*The teams were great fun to work with and a credit to their schools and teachers. The support the event receives from the F1 community shows that we truly are working with the engineers of the future and I look forward to seeing some of these youngsters in the F1 paddock working amongst the F1 teams.*

*I congratulate all the students on their hard work and I hope each and everyone one of them enjoyed the experience in Singapore.*

**David Croft**  
Sky Sports F1® HD Commentator

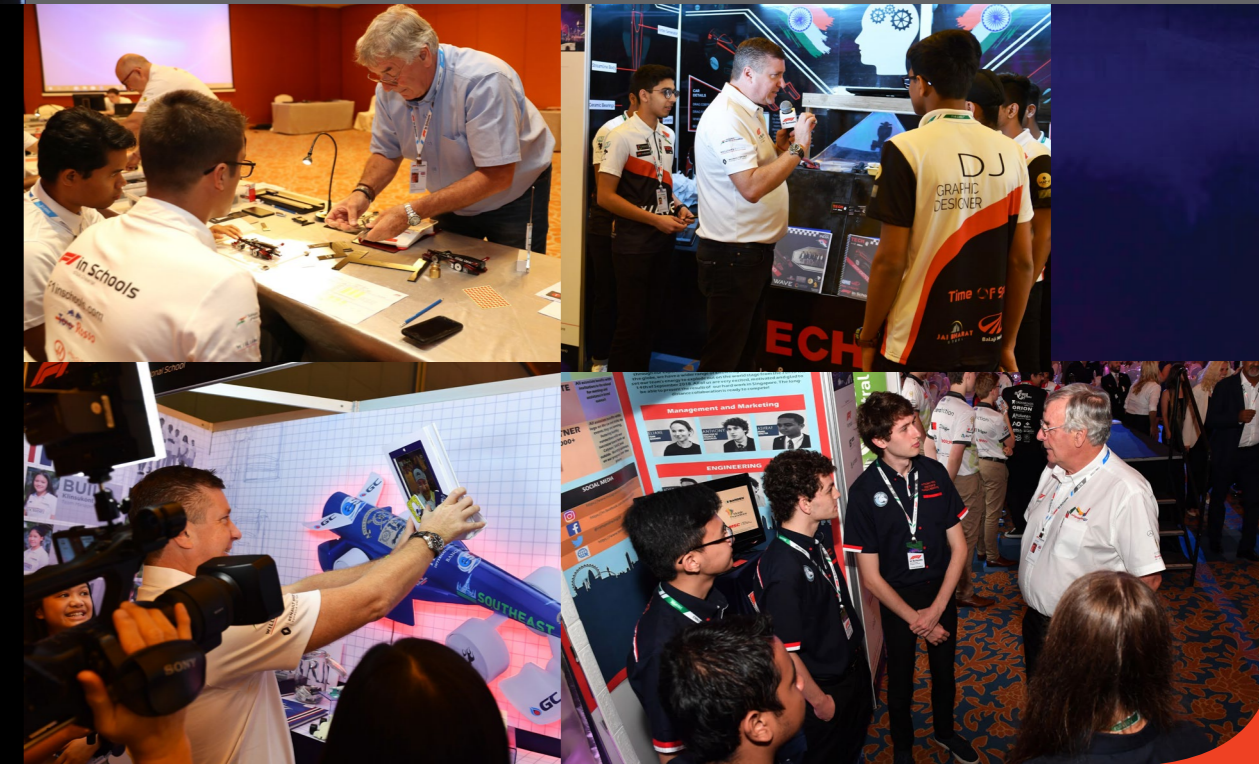



# The Challenge



## 1 - FORM AN F1 IN SCHOOLS™ TEAM

A team is formed of three - six students, with a team name, allocated job roles; Team Manager, Manufacturing Engineer, Design Engineer, Graphic Designer and Resource Manager.....The team then register for the regional finals.

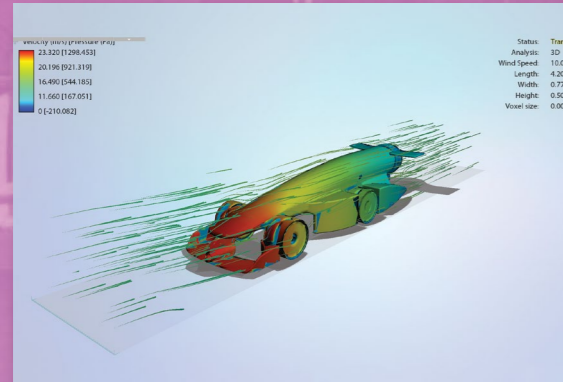

## 4 - ANALYSE AUTODESK

Aerodynamics are analysed for drag coefficient in a Virtual Reality Wind Tunnel using Computational Fluid Dynamics software (CFD).

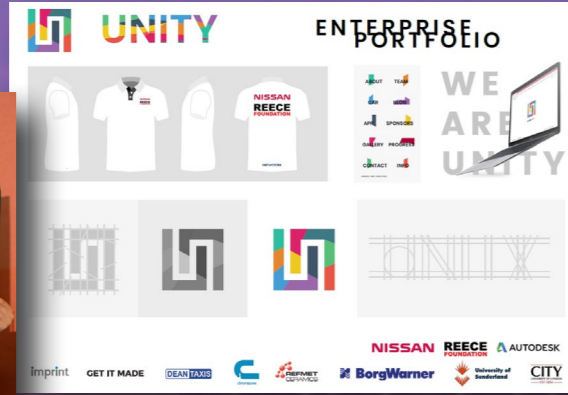

## 2 - BUSINESS AND SPONSORSHIP PLAN

The team prepare a business plan, develop a budget and raise sponsorship. Teams are encourage to collaborate with industry and create business links.



## 5 - MAKE

Using 3D CAM (Computer Aided Manufacture) software, the team evaluates the most efficient machining strategy to make the car.

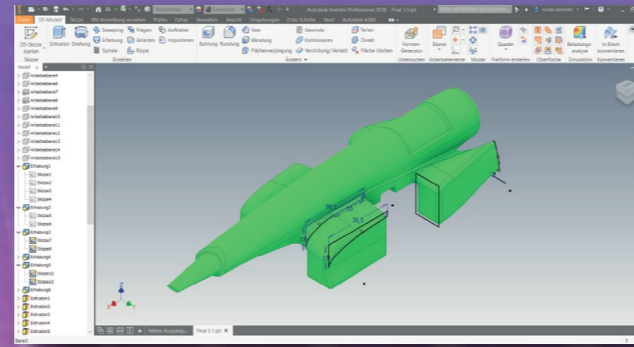

## 3 - DESIGN AUTODESK

Using 3D CAD (Computer Aided Design) software, the team designs an F1 car of the future to the specification set by the International Rules Committee, just like in Formula 1.



## 6 - TEST

Aerodynamics are tested in air trace visualisation tunnels. Aerodynamics is a major focus for all teams involved in the world of Formula 1 and can make the difference to a winning team. Students can fine tune designs to optimise speed and drag co-efficiency.



## 7 - PIT BOOTH

Teams put together an informative display showing their work through all stages of the competition, also incorporating their team identity.



## 10 - VERBAL PRESENTATION

Teams prepare a presentation to perform to a panel of judges covering all aspects of the challenge. This is presented within a set time limit (10 mins).



## 8 - SCRUTINEERING

Cars are submitted to parc fermé where the judges scrutinize every dimension to check they comply with the Rules and Regulations.



## 11 - PORTFOLIOS JUDGING

The teams put together two 10 page A3 portfolios documenting their project.



## 9 - ENGINEERING JUDGING

Judges question teams on how their car has been manufactured and why particular designs were chosen.



















## 12 - RACE

Teams are judged on car speed, as well as supporting evidence of their design, verbal presentation and marketing display stand in "the pits".

















Teams put the cars to their ultimate test by racing them over a measured distance with the F1 in Schools 20m elevated track and F1 in Schools race system.



## Competing Teams



















TEAM NO.	TEAM NAME	COUNTRY	SCHOOL
 T01	<b>Origin</b>	England	Robert May's School
 T02	<b>ANDROMEDA</b>	Jordan	Islamic Educational College
 T03	<b>Vortex Racing</b>	Cyprus	The Heritage Private School
 T04	<b>Team Nemesis</b>	Greece	Arsakeia Junior & Senior High Schools Of Patras - High School Of Xylokastro
 T05	<b>Team Matadors</b>	India	Amity International School
 T06	<b>Brazilian Six</b>	Brazil	Colégio Vértice
 T07	<b>Nam Phong Racing</b>	Vietnam	British International School, Ho Chi Minh City
 T08	<b>Triones</b>	China	Shenzhen College of International Education & Beijing Yucai School
 T09	<b>AeroFlow Racing</b>	United States	Wheeler High School
 T10	<b>Iota</b>	Australia	Tumut High School
 T11	<b>Team Accelerace</b>	United Kingdom	Linlithgow Academy
 T12	<b>SPYKAR</b>	China	Shanghai Shixi High School & Shanghai Dazhong Technical School
 T13	<b>Team Segel</b>	Brazil	Colégio Vértice
 T14	<b>Drive</b>	Wales	Ysgol Gyfun Llangefni
 T15	<b>Team Nihon University - Amuse</b>	Japan	Nihon University Buzan Girls' Senior & Junior High School
 T16	<b>Zero Friction</b>	Australia	Trinity Grammar School

## Competing Teams

TEAM NO.	TEAM NAME	COUNTRY	SCHOOL
 T17	<b>Tempest</b>	Malaysia & United Kingdom	Sultan Abdul Hamid College & Colyton Grammar School
 T18	<b>Feroxidus</b>	Singapore	Raffles Girls' School
 T19	<b>Team Phoenix</b>	Japan	Fukui Senior High School
 T20	<b>Team B.E.S.T.</b>	Brazil	Four C Bilingual Academy
 T21	<b>GEMS NEUTRINO</b>	United Arab Emirates	Cambridge International School
 T22	<b>Unity</b>	United Kingdom	Emmanuel College
 T23	<b>BWT Stream</b>	Austria	HTL Steyr and Vienna International School
 T24	<b>Fenix</b>	Mexico	CONALEP Dzitbalche, Calkini
 T25	<b>Arion</b>	Cyprus & Greece	The English School, Cyprus & Greek German School of Athens, Greece
 T26	<b>Kochasri Racing</b>	Thailand	Harrow International School
 T27	<b>Slipstream</b>	Cyprus	The English School Nicosia & The Falcon School Nicosia
 T28	<b>Entente</b>	Australia	Haileybury College and Methodist Ladies' College
 T29	<b>Malaxa</b>	Romania	British School of Bucharest
 T30	<b>Blu Comet Racing</b>	United Arab Emirates	GEMS World Academy Dubai
 T31	<b>Team Tech No Logic</b>	India	Genesis Global School
 T32	<b>CJJ AutoVincio</b>	Ireland	St Brigid's College



## Competing Teams

TEAM NO.	TEAM NAME	COUNTRY	SCHOOL
 T33	<b>Unity Racing</b>	Germany	Gymnasium Grootmoor
 T35	<b>Imparables JS</b>	Mexico	Cecyte Hermosillo IV
 T36	<b>Fm-1 Racing</b>	Ireland	Sutton Park School
 T37	<b>Polaris</b>	Germany	Märkisches Gymnasium Iserlohn
 T38	<b>Team Impulse</b>	India	The British School
 T39	<b>Horizon</b>	Australia	Brighton Secondary School
 T40	<b>PERSPECTIVE</b>	United States	Palmetto High School
 T41	<b>Lucendi</b>	Malaysia	Garden International School
 T42	<b>Lux</b>	China	The Experimental High School Attached to Beijing Normal University
 T43	<b>Aero9</b>	Malaysia	Smk Seksyen 9 Shah Alam
 T44	<b>NOVA</b>	Mexico	Colegio de Bachilleres del Estado de Sonora
 T45	<b>TNT Racing UDG</b>	Mexico	Preparatoría de Tonalá
 T46	<b>Alacrity Project</b>	Greece	Erasmios Greek And German School & 2nd General Lyceum Of Pallini
 T47	<b>Velocity Racing</b>	Scotland	Inveralmond Community High School
 T48	<b>AL6PH</b>	Thailand	Singapore International School of Bangkok
 T49	<b>dex-rac Racing</b>	Malaysia	Sultanah Hajjah Kalsom Secondary School
 T50	<b>Pursuit Racing</b>	Thailand	Amnuay Silpa School
 T51	<b>Zeus</b>	Greece	Arsakeio Tositseio Ekalis & Ekpedefteki Anagennisi

## 2018 World Finals - VIP Opening



The first day kicked off with a 'flag-off' F1 in Schools™ race with Justinian Habner, Deputy Director British High Commission Singapore, putting his skills to the test against F1 in Schools™ Founder and Chairman, Andrew Denford.



Students then began the intensive judging sessions with the 50 teams, representing 22 countries, under the scrutiny of the experienced panel of judges, all vying to claim the title F1 in Schools world champions 2018.

The opening ceremony included the unveiling of the stunning new Formula 1 F1 in Schools world champions trophy. The impressive sculptural design features the Formula 1 brand logo under a metallic silver F1 in Schools race car. The model featured is last year's world champions race car designed by the Australian Hyperdrive team.

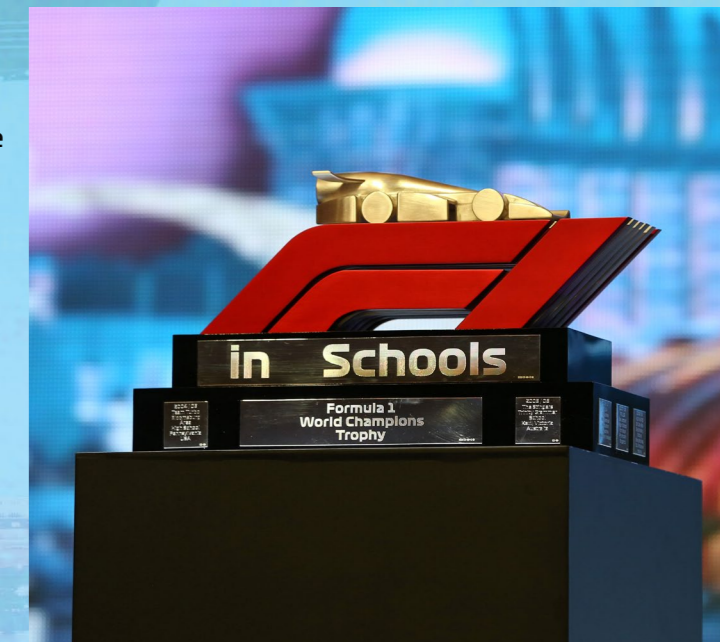



## Competition - Day 1

The opening day of the competition, with verbal presentations, portfolio, pit display, engineering judging sessions, as well as the intense pressure of F1 in Schools™ track racing, gave the teams their first taste of competing at the highest level of this acclaimed global education challenge.



## Competition - Day 2



Australia broke the one-second barrier in the opening day of the competition. Horizon from Brighton Secondary School, Adelaide posted a time of 0.997 seconds, beating a USA team, AeroFlow Racing, with a time of 1.049 seconds, just 0.001 seconds ahead of third placed team, TNT Racing UDG from Mexico.



Judging continued on the second day



# Unilever Williams Engineering Academy Assessment Centre & Cultural Event



A rigorous selection process with a distinguished panel of Williams's personnel led by Dave Redding, Race Team Manager, assessed 25 talented F1 in Schools™ world finalists earlier this week. Launched in 2015, the students benefit from this remote e-learning programme with the successful candidates receiving support, training and guidance to underpin their engineering education.

The rest of the world finalists were treated to a Cultural Festival where they took part in a wide range of activities giving them a real sense of the Singaporean culture. Activities included Batik Art, Copper Tooling, Chinese Mask Painting, Cajon Drumming, Ethnic Percussion, Traditional Toy Making and Bollywood Jam Dancing.

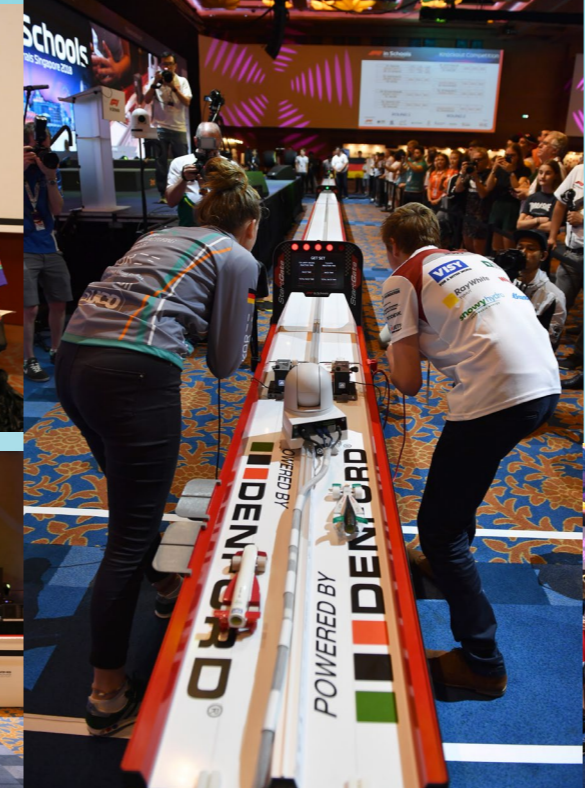

The final day of competition was also host to the exciting Knockout Racing Competition.

The Knockout Racing always provides a great spectacle but it's extremely competitive, particularly for the student selected to 'drive' the team's car. It's all about reaction times as well as a fast car to beat the rest of the teams and take the win.



The final head to head battle pitting TNT Racing UDG from Mexico against Lux from China meant they faced each other in the final showdown race, held at Awards Celebration Gala Dinner.





# Awards Celebration **Gala Dinner**

The glittering awards extravaganza, attended by over 650 guests including guests of honour Chase Carey, Chief Executive Officer, Formula 1® and Peter Ong, Chairman, Enterprise Singapore, the 50 world finals teams, teachers, dignitaries and key Formula 1® paddock personnel celebrated the achievements of the F1 in Schools™ world finalists, the future Engineers and professionals of the Formula 1® industry.



Guests of Honour Chase Carey and Peter Ong raced at the start of the night with Chase narrowly beating Peter in the 'celebrity race'.



Prior to presenting the trophy to the world champions Chase said, "I want to thank and congratulate tonight's competitors, who are the most impressive group of young people that I have ever met in many years. Your energy and passion are incredible and my hope is that some of you will end up in Formula 1 at some point in the future, but what is clear is the world is yours. You are an incredibly talented group of individuals and all of you have exciting futures ahead of you. If the future of the world is based on our youth, the future of the world is in good hands. I cannot be more impressed with the geographic spread, the diversity, the number of young women that are engaging in this activity, it's just incredible. We couldn't be more excited about the future, we couldn't be more excited



about working with F1 in Schools to continue to build on what's in place."

In front of the Awards Dinner guests Team Lux from China took victory in the Knockout Racing Competition Finale. A total of 22 awards were presented, rewarding the outstanding achievements of the F1 in Schools™ 2018 world finals teams.





## 3rd Place & 2nd Place



# B

THIRD PLACE

**Perspective**

Palmetto High School  
United States



supported by



# 2

SECOND PLACE

**CJJ AutoVinco**

St Brigid's College  
Ireland



supported by



## WORLD CHAMPIONS



# 1

FIRST PLACE



**Horizon**

Brighton Secondary School  
Australia

supported by



The Horizon team with James Gurney (16), Luke Battjes (18), James Lloyd (16), Jae-Marie Elliss (16), Tom Lightfoot (15), Luka Moase (15) won scholarships for City, University of London and UCL Engineering, as well as being guests of Formula 1 with complimentary four-day paddock access to the FORMULA 1 2018 SINGAPORE AIRLINES SINGAPORE GRAND PRIX and presentation of the new F1 in Schools trophy, in front of the F1 photographers, on the podium at the Marina Bay circuit.

The Australian team also won the Best Engineered Car Award supported by Williams Racing and the Fastest Car Award, supported by Mercedes-AMG Petronas F1 Team, with the team's car clocking a time of 0.997 seconds on the F1 in Schools track, the only team at this year's World Finals to post a sub one-second time. Horizon were also nominated for the Research and Development Award.

Horizon Team Manager, James Gurney, said of winning, "We're feeling on top of the world. We knew there were so many competitive teams around but we knew how much work we had done and were just hoping that we had done enough. For some of us it's been three or four years working on this, but we've had late nights and an amazing journey. Well done to all the other teams too, they've been very special and we're going to have lifelong friends and memories."

Of the team's success he said, "The engineering behind our car was very precise and we were constantly improving and refining it to make the best product possible. We were perfectionists, making sure nothing was half hearted, the effort and dedication we put in, were the key for us. The experience will be something we'll hold for the rest of our lives."

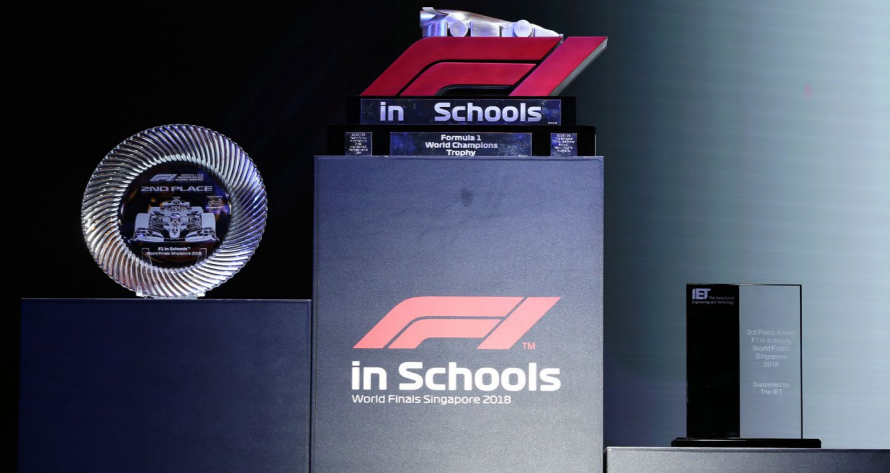



# Award Winners



**Shell**  
**The Best International Collaboration Team Award**  
 supported by Shell  
**ARION**  
 The English School, Cyprus & Greek German School of Athens, Greece



**McLaren**  
**Research and Development Award**  
 supported by McLaren  
**PERSPECTIVE**  
 Palmetto High School - United States



**RENAULT SPORT FORMULA ONE TEAM**  
**Innovative Thinking Award**  
 supported by Renault Sport Formula One Team  
**GEMS NEUTRINO**  
 Cambridge International School - United Arab Emirates

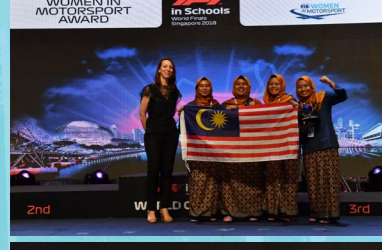

**FIA WOMEN IN MOTORSPORT**  
**Women in Motorsport Award**  
 supported by FIA Women in Motorsport  
**dex-rac Racing**  
 Sultanah Hajjah Kaisom Secondary School - Malaysia



**Sauber F1 Team**  
**Resilience Award**  
 supported by Sauber F1 Team  
**Imparables JS**  
 Cecyte Hermosillo IV - Mexico



**WILLIAMS RACING**  
**Best Engineered Car Award**  
 supported by Williams Racing  
**Horizon**  
 Brighton Secondary School - Australia

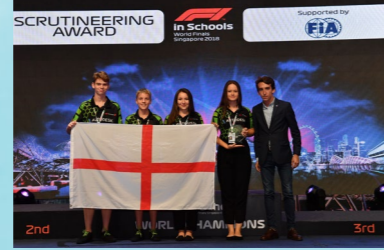

**FIA**  
**Scrutineering Award**  
 supported by FIA  
**Origin**  
 Robert May's School - England



**Haas F1 Team**  
**Team Sponsorship & Marketing Award**  
 supported by Haas F1 Team  
**CJJ AutoVincO**  
 St Brigid's College - Ireland



**ASTON MARTIN Red Bull RACING**  
**Chair of Judges Recognition of Achievement Award**  
 supported by Red Bull Racing Formula One Team  
**Team B.E.S.T.**  
 Four C Bilingual Academy - Brazil

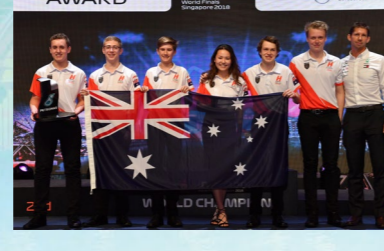

**AMG PETRONAS MOTORSPORT**  
**Fastest Car Award**  
 supported by Mercedes-AMG Petronas Motorsport  
**Horizon**  
 Brighton Secondary School - Australia



**Scuderia Toro Rosso**  
**Pit Display Award**  
 supported by Scuderia Toro Rosso  
**Feroxidus**  
 Raffles Girls' School - Singapore



**Formula 1**  
**Verbal Presentation Award**  
 supported by Formula 1  
**Unity**  
 Emmanuel College - United Kingdom



**Acronis**  
**Enterprise Portfolio Award**  
 supported by ACRONIS  
**Unity Racing**  
 Gymnasium Grootmoor - Germany

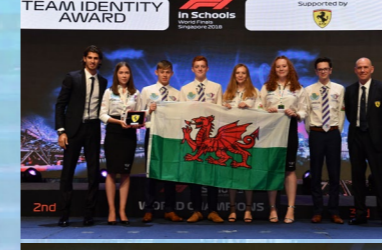

**Ferrari**  
**Team Identity Award**  
 supported by Scuderia Ferrari  
**Drive**  
 Ysgol Gyfun Llangejni - Wales



**Force India**  
**Outstanding Sportsmanship Award**  
 supported by Sahara Force India Formula One Team  
**Lux**  
 The Experimental High School Attached to Beijing Normal University - China



**MASTEREIGN ENRICHMENT GROUP**  
**Team Website Award**  
 supported by Mastereign Enrichment Group  
**Nam Phong Racing**  
 British International School, Ho Chi Minh City - Vietnam



**PIRELLI**  
**Knockout Competition Winners**  
 supported by Pirelli  
**Lux**  
 The Experimental High School Attached to Beijing Normal University - China

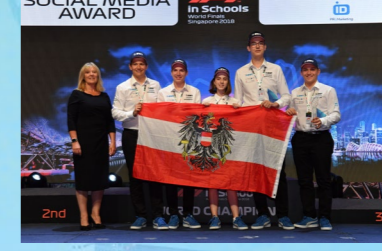

**ID PR:Marketing**  
**Social Media Award**  
 supported by ID PR  
**BWT Stream**  
 HTL Steyr and Vienna International School - Austria



**motorsport NETWORK**  
**Moment of the Week Award**  
 supported by Motorsport Network  
**NOVA**  
 Colegio de Bachilleres del Estado de Sonora - Mexico



# Unilever Williams Engineering Academy Class of 2018



The evening included the announcement of nine related students who won coveted places at the Unilever Williams Engineering Academy.

Students from England, Vietnam, Ireland, Mexico, Wales and the USA, were announced by Nicola Salter, Group HR Director, Williams and Dave Penrith, Chief Engineer, Unilever, on stage at the awards. This is the fourth intake to the Academy that takes its students exclusively from F1 in Schools World Finals events each year.



## Singapore GP Visit &

## Pit Lane Walk



The students had a fantastic day visiting the Singapore Grand Prix Marina Bay Circuit where they were treated to an exclusive coach tour of the circuit, led by the official F1® safety car. The lap concluded with a group photo on the start and finish straight with the famous Singapore Flyer in the background.

The VIP treatment didn't end there, the students were then given access to the F1 Pit Lane for an exclusive F1 in Schools Pit Lane Walk courtesy of the circuit and Formula 1. The students

were able to see behind the scenes for an unforgettable experience.

The teams who won the F1 team awards were hosted by the F1 teams in their pit garages and given a behind the scenes tour and in-depth look at the cars up close.



# Winning teams visit the **Formula 1® Paddock**



Some teams stayed on in Singapore to attend the **FORMULA 1 2018 SINGAPORE AIRLINES SINGAPORE GRAND PRIX.**

The award winning teams were also given exclusive VIP entry to the F1 paddock where they were each given a behind the scenes tour.





# World champions hosted in the Formula 1® Paddock



Team Horizon, the newly crowned world champions were guests of Formula 1 with VIP paddock passes for the entire weekend as well as extremely exclusive Grid Access for race day, a truly once in a lifetime experience.



# Women in Motorsport



F1 in Schools is proud to deliver such an exciting initiative that attracts so many females into the challenge. This year 40% of participants were girls.











Supported by:



Held in:



f1inschools.com

#F1SWF @F1inSchoolsHQ

F1 In Schools Ltd.  
Savoy Place  
London WC2R 0BL  
f1inschools.com  
T +44 (0) 20 7344 8449 E contactus@f1inschools.com